

TYPE3 (HEIDENHAIN)	POWER(CONT./SHORT)	kW	24(CONT.)/32(S6 40%)
	MAX. SPINDLE SPEED	r/min	12,000
	BASE SPEED	r/min	2,420
	MAX. TORQUE (SHORT TERM)	N·m	94.7(CONT.) / 126.27(S6 40%)
	ORIENTATION		BUILT-IN SENSOR
	POWER TRANSMISSION		BUILT-IN DRIVE

4.1

Main specifications

ITEM		UNIT	SPECIFICATION	
			FANUC	HEIDENHAIN
RAPID TRAVERSE	X AXIS	m/min	40	
	Y AXIS	m/min	40	
	Z AXIS	m/min	40	
ACCELERATION / DECELERATION TIME	X AXIS	ms	250	
	Y AXIS	ms	200	
	Y AXIS	ms	200	
MAX. CUTTING FEEDRATE	X,Y,Z AXIS	mm/min	20,000	
	B,C AXIS	deg/min	7,200	
RATED THRUST FORCE AT STALL ⁽¹⁾	Z AXIS	kN	13.3	
BALL SCREW (DIAMETER x LEAD)	X AXIS	mm	63 x 40	
	Y AXIS	mm	50 x 20	
	Z AXIS	mm	50 x 20	
ACCURACY	Positioning(X,Y,Z)	mm	±0.005/FULL STROKE	
	Repeatability(X,Y,Z)	mm	±0.002	
DRIVE MOTOR	POWER	X AXIS	6	9.6
		Y AXIS	7	7.2
		Z AXIS	9	9.9
FEEDBACK SYSTEM	ABSOLUTE PULSE CODER		X,Y,Z,B,C	

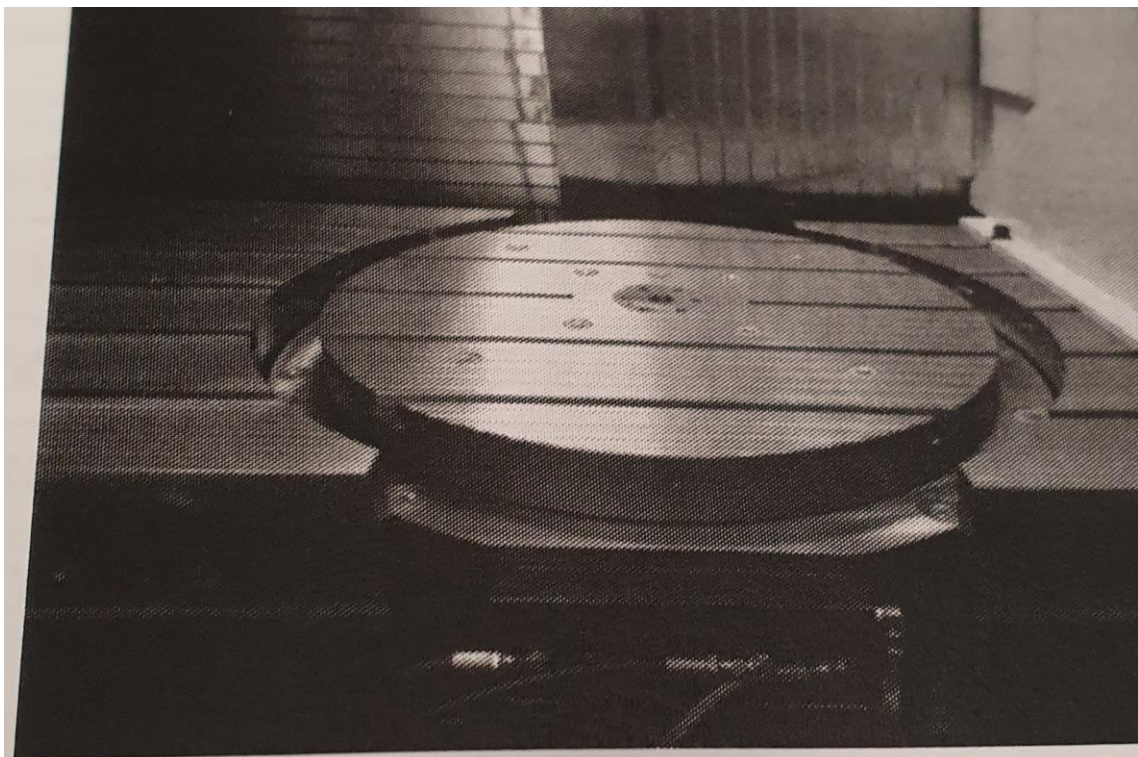
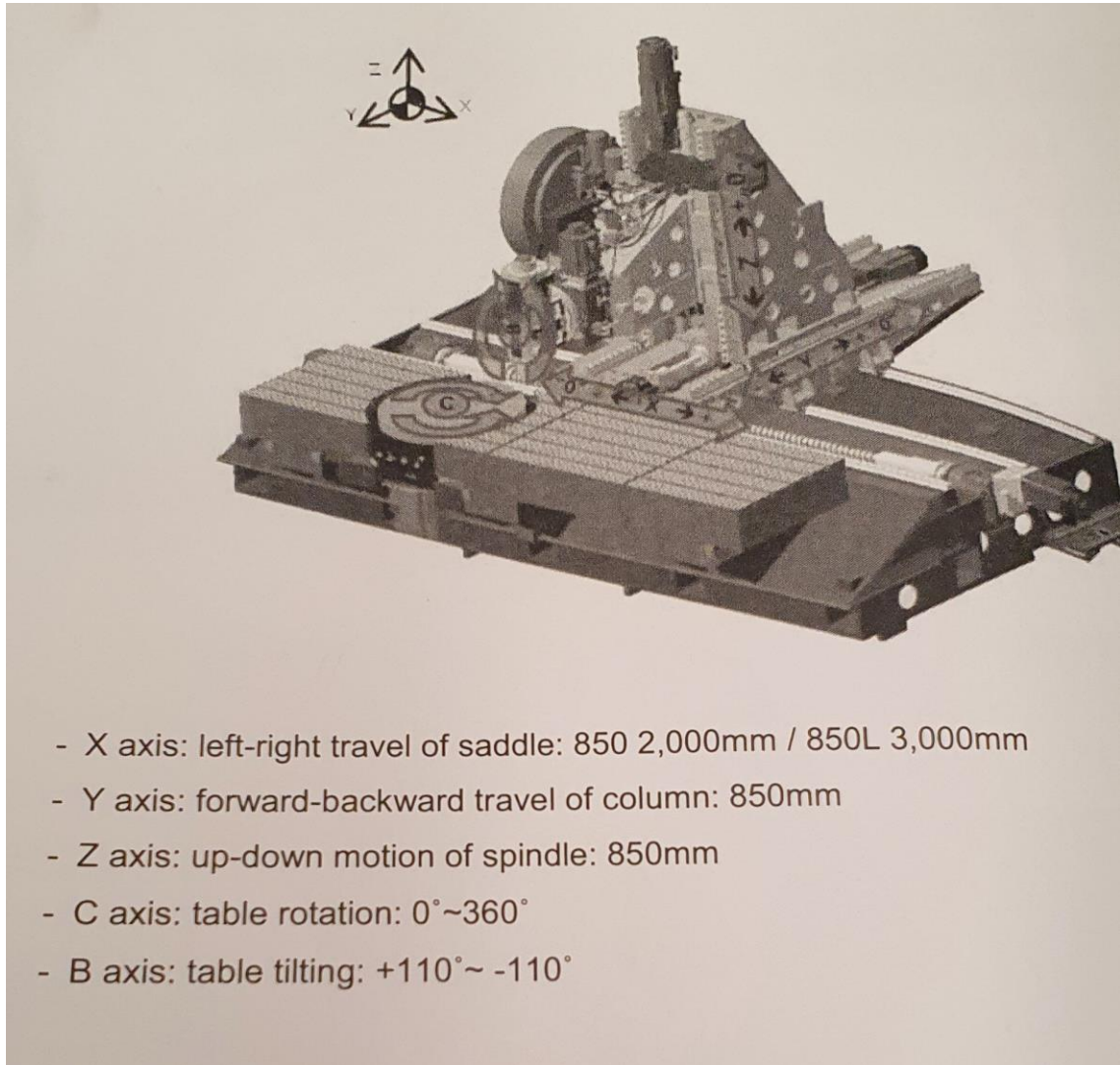

D800